

FEATURES

- 16-Channels voltage input
- Adjustable transducer power source
- Ethernet control and data interface
- 10 kHz analog bandwidth
- Programmable 10 to 24,000 samples per second per channel
- 10 Hz to 3 kHz filters, 80 dB/octave
- IRIG A, B & G time decoding and stamping
- Synchronized sampling of multiple bricks to 1 microsecond
- 0.05% or better accuracy over full gain and temperature range
- Rugged and sealed for tough environments
- 20 to 30 Volt DC power



The Model 7220 is a high-performance, high-accuracy voltage scanner and member of the 7200 series of ruggedized measurement systems. A network appliance, it provides input sensitivities from 10 millivolts to 10 Volts full scale. The rugged enclosure is designed for installation in wind tunnels, engine test stands and other facilities where it is desired to locate the data acquisition close to the test article reducing installation and cable cost and improving signal quality and reliability.

Fully self-contained the 7220 provides regulated power for transducers that have built-in electronics. The transducer power is programmable from 0 to 15 Volts. The input signals are amplified, filtered to remove signal components that could produce alias errors and digitized to 24-bit resolution. The digitized signals are digitally processed providing multiple sample rates, 80 dB/octave FIR filters and 32-bit floating point outputs in millivolts referred to input, millivolts referred to output or user defined engineering units.

The inputs are digitized, processed and output at 10 to 24,000 samples per second as selected for individual channels. A digital signal processor (DSP) provides low-pass filtering selectable from 10 Hz to 3,000 Hz with 80 db/octave attenuation. The DSP can be custom programmed to provide alternate filter responses and perform application specific signal processing.

Each 7220 has a 100BaseT Ethernet interface for control and data output, which simplifies system wiring and provides remote and distributed operation. IRIG time may be employed to synchronize sampling on multiple units within 10 microseconds or a timing pulse may be used to achieve better than 1 microsecond time alignment. Multiple Bricks with up to 4,096 channels may be connected on a single Ethernet LAN.

The case features interchangeable end plates that provide fully sealed, ambient air or forced air cooling. Forced air cooling provides the capability to operate over a wide temperature range according to application requirements. Occupying less than 500 cubic inches and weighing less than 14 pounds the 7220 can be installed in locations previously not suitable for data acquisition systems. The Ethernet interface and IRIG timing make it easy to distribute units throughout the test facility minimizing sensor cabling and installation costs.

The Model 7220 does not sacrifice performance. In fact, it features higher accuracy than most systems designed for a laboratory environment. That's because it is self calibrating, taking into account temperature variations. Accuracy is better than 0.025% for gains up to 200 and 0.05% for gains above 200 over the temperature range -20°C to +50°C, which can be extended to higher temperatures by forced air cooling.

Calibration and performance verification is accomplished by PANEL72 Maintenance and Calibration software. The ACS2000 Automatic Calibration System automates performance verification and periodic instrument calibration.

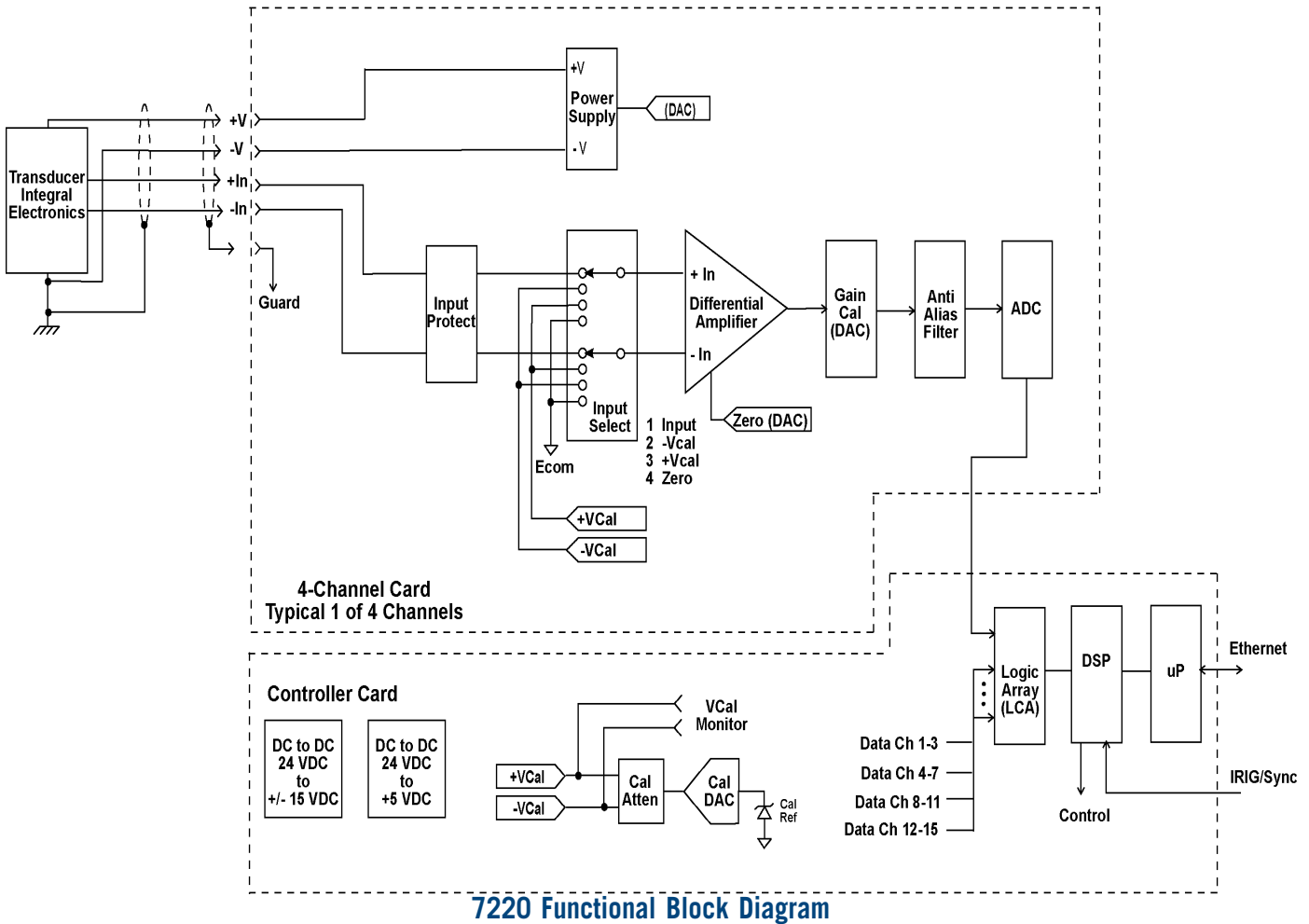

Cabling transducers to a remote data acquisition system is costly and may require intermediate signal connections that introduce reliability problems. In addition, the transducer and cable impedance can filter the signal, attenuating high frequency signal components. Locating data acquisition

hardware near transducers at many test facilities has required specially constructed and environmentally conditioned enclosures. Using the 7220, the data acquisition can be installed in unprepared locations and the only external connections are power, timing and Ethernet.

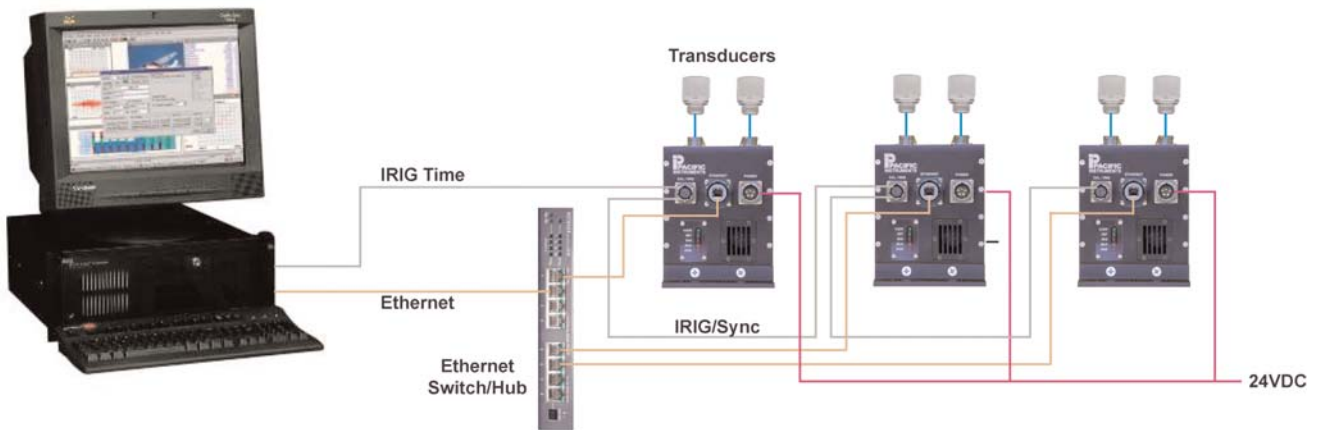

Typical 7220 Installation

ACCURACY

The 7220 maintains $\pm 0.025\%$ uncertainty ($\pm 0.05\%$ for gains above 200) over the full temperature range by continuously correcting for temperature induced gain and zero variations. It is initially calibrated over the full temperature range with gain and zero correction vectors stored in non-volatile memory. An internal sensor determines the correction vectors applied to the data according to the device temperature. Software is available for automatic recalibration. Voltage calibration, using an internal precision voltage reference is provided to confirm accuracy and perform health checks.

TRANSDUCER POWER

Each channel has an independent, regulated power source that provides operating power for transducers with internal electronics. This power source may be programmed for 0 to +15 Volts output regulated to 0.1%. It can supply up to 50 mA and is current limited so it will not be damaged by a shorted output.

INSTRUMENTATION AMPLIFIER

The inputs are protected up to ± 50 Volts differential and common mode. They are applied to a high-impedance, programmable gain, differential instrumentation amplifier. The amplifier has programmable gains from 1 to 1,000 providing full-scale input ranges of ± 10 mV to ± 10 Volts. Calibrated gain steps with $\pm 0.02\%$ accuracy are provided or the amplifier gain may be continuously programmed. Autozero maintains the amplifier output offset within ± 1 mV.

ANALOG TO DIGITAL

Conditioned and amplified transducer signals are digitized by a 24-bit resolution Sigma-Delta analog-to-digital converter that over-samples the analog signal enabling the use of a single-frequency anti-aliasing filter.

SAMPLING

Sampling is synchronized between channels and systems providing time aligned data. All channels are simultaneously sampled at the highest sample rate, 24 kS/s. The sample rate clock may be synchronized to IRIG A, B or G time. IRIG G time is generated by the unit connected to the external IRIG source or designated as the master time source if external IRIG is not used. Distributed to multiple systems it maintains channel to channel time skew under 10 microseconds for channels in the same or other units using the same master time source. Alternatively a TTL Sync input may be used to maintain time skew of less than 1 microsecond. If the timing signal is not present or lost during acquisition sampling will continue at the last programmed rate using an internal clock.

FILTER

Finite Impulse Response (FIR) filtering is provided. Eighty sets of 128 FIR filter coefficients are available in each 7200 providing an extensive selection of filter frequencies and characteristics. The coefficients are user programmable, and each coefficient is 18 bits in length. The filters may be loaded with customer-specified default coefficients providing logical filter cutoff selections and characteristics. The default filter frequencies and characteristics are easily changed to satisfy future requirements.

DATA

Data are output on the Ethernet interface. The output data is 32-bit floating point format and can be chosen via programming to be Volts, millivolts or microvolts referred to input or output or user defined engineering units derived from a polynomial expression. Each unit can output data from all channels at the maximum sample rate. Data rates in excess of 7 million samples per second are achievable from combined 7200 systems on a single LAN.

PROGRAMMING

All operating parameters can be set and queried using the extensive, built-in command set. Setup information is saved in password protected EEPROM memory on board, and it is automatically restored when power is applied or the system reset. The command set is well documented, and source code programming examples are provided.

CALIBRATION AND PERFORMANCE VERIFICATION

PANEL72 is Pacific's maintenance and calibration software. It may be used to troubleshoot installation problems and calibrate the 7220. The ACS2000 is an automated calibration system that performs performance verification, calibration and accuracy certification to NIST traceable standards.

COMMUNICATIONS

Initializing communication with the 7200 is simple. Commands are included that enumerate the 7200 devices on the network. After the enumeration operating software creates a socket interface between itself and each 7200. Simple Send and Receive network commands are used to communicate. Status LEDs that assist with initial setup are located on the connector end of the enclosure. Multiple systems, up to 4,096 channels, may be connected to a single Ethernet LAN.



SPECIFICATIONS

TRANSUCER POWER

Range.....Programmable from 1 to 15 Volts in 1-Volt steps $\pm 0.1\%$.
 Current.....50 mA limited to 70 mA maximum.
 RegulationEach channel individually regulated. $\pm 0.1\%$ over input voltage range and no-load to full load.

INPUT

Configuration2 to 4 wire inputs, input (2), power (2) with shield.
 Input Impedance ..50 Megohms, shunted by 500 pF.
 Input Protection ± 50 Volts differential, ± 50 Volts common mode without damage.

CALIBRATION

GainVoltage substitution using an internal programmable precision reference with $\pm 0.02\%$ accuracy. Output of the internal reference is provided on a connector for NIST traceable calibration.
 ZeroAmplifier input disconnected and shorted for zero calibration.

AMPLIFIER

Range..... ± 10 mV to ± 10 Volts.
 GainProgrammable from 1 to 1,000 with 0.02% resolution.
 Gain StepsFourteen calibrated gain steps are provided:1, 2, 3, 5, 10, 20, 30, 50, 100, 200, 300, 500, 1000 with $\pm 0.02\%$ accuracy.
 Gain Stability $\pm 0.01\%$ for 30 days, $\pm 0.001\%/^{\circ}\text{C}$ compensated. $\pm 0.05\%$ for 30 days, $\pm 0.005\%/^{\circ}\text{C}$ without compensation..
 Linearity $\pm 0.01\%$.
 Common Mode60 dB plus gain in dB to 110 dB, DC to 60Hz.
 CM Voltage ± 10 Volts operating.
 ZeroAutomatic zero to ± 2 μV RTI or ± 1.0 mV RTO whichever is greater.
 Zero Stability $\pm 5\mu\text{V}$ RTI, $\pm 1\text{mV}$ RTO at constant temperature, $\pm 1\mu\text{V}$ RTI/ $^{\circ}\text{C}$, $\pm 0.2\text{mV}$ RTO/ $^{\circ}\text{C}$. Short term: $\pm 2\mu\text{V}$ RTI, $\pm 0.4\text{mV}$ RTO for 8 hours (without correction).
 Source Current ± 10 nA, ± 0.05 nA/ $^{\circ}\text{C}$.
 Noise (10 kHz).....2.0 μV RTI plus 0.3 mV RTO, RMS.
 Bandwidth10 kHz(-3dB).
 OverloadRecovery time is 120 μs to within $\pm 0.1\%$ for a 10 times overload to ± 10 Volts.

ANALOG-TO-DIGITAL CONVERTER

Resolution24-bits.
 Sample Rate.....24K samples per second per channel.
 Individual channels may be programmed to output data at rates from 10 Hz to 24 kHz..

ACCURACY

SystemAfter calibration the system maintains better than $\pm 0.025\%$ full scale (2-sigma) uncertainty for gains up to 200 and $\pm 0.05\%$ full scale (2-sigma) uncertainty for gains above 200 over the operating temperature range.

FILTER

TypeFinite Impulse Response (FIR) with 128 coefficients.
 ResponseProgrammable from 10 Hz to 3 kHz with 80 dB/octave attenuation above cut-off.

TIME

SourceIRIG A, B or G.
 Level1-Volt peak-to-peak nominal.
 Sync.....Synchronized sampling of multiple bricks to within 10 microseconds without separate Sync.
 OutputDays, Hours, Minutes, Seconds, Microseconds may be output at selected positions in the data stream. IRIG G output provided for multiple module synchronization.

INTERFACE

Interface.....Ethernet 100BaseT, TCP/IP, control and data.
 Data FormatFloating point, 32-bits. Output available in engineering units, Volts or millivolts.
 Aggregate RateSupports all sixteen channels at the highest sample rate.
 Sync.....TTL input may be used to synchronize sampling of multiple bricks to within 1 microsecond.
 OperationSupported by PI660 and PANEL60 software.

GENERAL

ConnectorsMIL, 1/4-turn locking.
 Temperature-20 $^{\circ}\text{C}$ to +50 $^{\circ}\text{C}$ operating. ambient air. -20 $^{\circ}\text{C}$ to +40 $^{\circ}\text{C}$ operating. fully sealed. Extended temperature range using forced air cooling. consult Pacific technical support.
 Vibration/Shock.....MIL-STD-810F.
 MoistureNEMA 13.
 Power20 to 30 VDC.
 Dimensions.....5.25" Wide, 7.75" High, 12" Deep excluding mounting flanges
 Weight14 lbs.

ORDERING INFORMATION

722016-Channel High-Accuracy Voltage Scanner.