

*Easy to use, intuitive software saves valuable time without compromising hardware performance or test methodology. If you measure strain, pressure, temperature, vibration, position, voltage, current or other physical parameters, PI660 provides the software solution you need*



- **Ready to run or custom application-** Use the PI660 DLL with Visual Basic, LabView, C, C++ or other Window's programming language to customize acquisition and control.
- **Database programming-** Use any Access compatible spreadsheet or database to program system or use PI660's built-in menus.
- **Intuitive operation-** Menu programming and on-screen toolbars reduce setup time and operator errors.
- **Real-time displays-** Tabular and graphical data display windows on the operator and networked display workstations including a 9-monitor "data wall".
- **Dynamic data displays-** Oscilloscope and 4096-point FFT with cursors and automatic peak tracking.
- **Automatic calibration-** Gain and engineering units calibration with user-defined procedures that automate and verify the calibration process.
- **Multiple sample rates-** Conserve storage space and reduce analysis time by recording channels at their required sample rates.
- **Switch data views-** Save multiple data display configurations and switch between the last two by a mouse click.
- **See recorded data-** Immediate playback to PI660's tabular and graphical data displays.
- **Export to third-party applications-** ASCII, dPLOT, DADiSP, Universal File Format, binary and many other formats.
- **Alarms-** Alarm limits can be visually indicated on many of the data displays by selecting colors to represent normal and alarm readings or indication.
- **Math engine-** The math engine is used to derive calculated parameters using data from up to nine measurement channels. Derived parameters may be displayed like regular data channels.
- **Operational Logging-** Operations may be logged to a text file recording the sequence of events that took place during setup and testing.
- **Configuration Logging-** Operating and calibration parameters may be logged to text files for viewing with text editor or spreadsheet.

# READY TO RUN OR DLL SOFTWARE

*PI660 offers two distinct approaches to data acquisition & display:  
a ready-to-run application or a custom interface*

## Ready to run application

Unlike general purpose programming languages, PI660 is ready for use out of the box and specifically tailored for transducer data acquisition and display. Versatile and easy to use, PI660's operator interface employs menus and toolbars to program DAS hardware and acquire and display data. Just configure PI660 for the installed hardware and your ready to go.

PI660's programming and setup screens self-configure for the installed hardware. A single screen handles all types of analog signal conditioning making it easy for the operator to navigate. Individual selections like gain, filter and excitation are chosen from drop-down menus configured for the installed module.

Toolbars provide quick selection of frequently used routines such as start and stop data preview and recording, playback, single scan, and data displays. Buttons also launch data plotting, export and analysis applications.

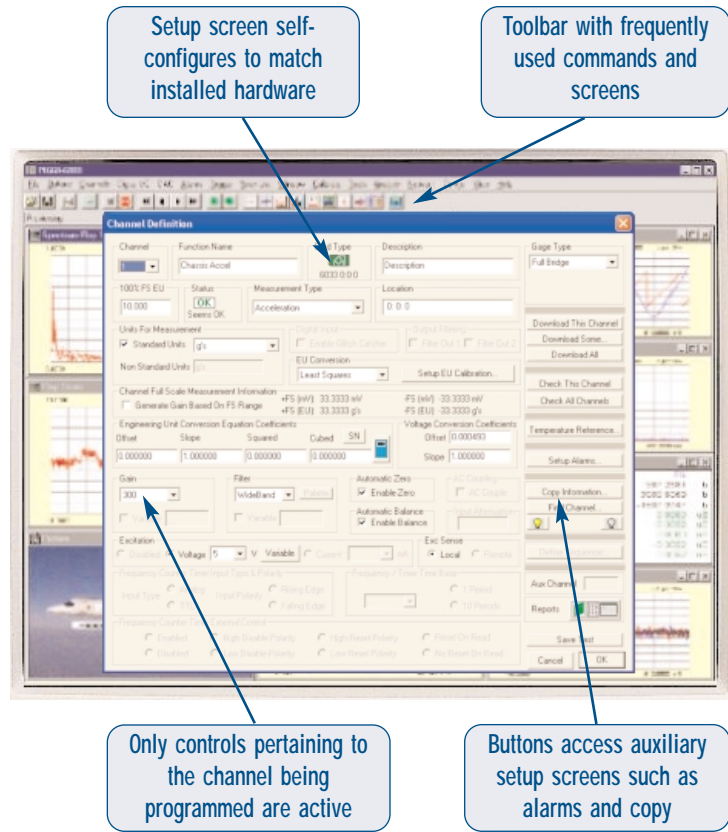

Design Visual Basic custom applications using PI660 CMD

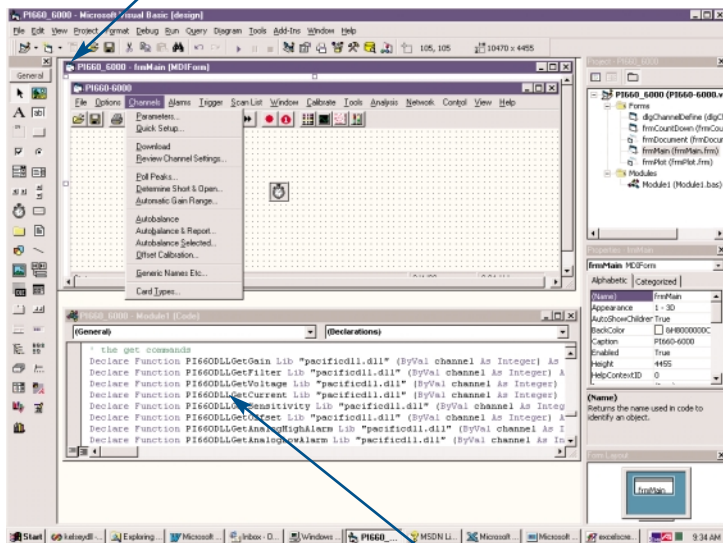

Calls to routines in PI660 DLL that implement DAS functionality

## Custom applications

Creating custom software applications is simple using the Component Module Dynamic Link Library (CMD) that is supplied with PI660XP and PI660XPS. Similar to but more powerful than an Application Programmer's Interface, the CMD facilitates custom applications that can provide facility and test control as well as support for third party hardware and software.

Any Window's programming software, Visual Basic, LabVIEW, HP VEE, Excel, C++ or C may be used to create custom applications that call high-level data acquisition and display functions in the CMD. For example one call opens the screen that programs channel parameters or sets sample rates. This means the application programmer does not need to create acquisition and display software and is free to concentrate on programming the test and facility operation.



## Smart-menu system programming - just point and click to setup, calibrate, record, view and export data

### **Open a previous test file or create a new test file to program a test**

Test files contain all programmed operating parameters, calibration and other information necessary to implement a test. Either PI660 or Access files may be used.

### **Automatic calibration saves time and assures accuracy**

Calibration results are automatically documented to assure traceability. Calibration "procedures" simplify programming for multiple similar measurements.

### **Test readiness verifies that settings are correct and system is ready to record**

Open the Test Readiness Review screen that contains an operator configured checklist and the status of each checked item.

### **Preview displays data without recording**

Preview starts data acquisition in the 6000's ring buffer with active alarms and displays. Measurement data is displayed on the operator workstation and sent to network display workstations.

### **View real-time data displayed on operator and client workstations**

Open, configure and arrange real time display windows while data is being recorded or played-back. Display update rates are adjustable.

### **Immediate viewing of recorded data by playback to displays**

Select fast, slow, forward, reverse or pause to view details. Go to a particular time or location in the test file. Search for specified signal criteria.

### **Switch display screens to view data in a different way.**

Any number of display screens may be configured and saved. Switch back and forth between two screens with a mouse click.

### **Saving the test file enables the test to be opened without reprogramming.**

To save time the saved test file can be modified and renamed for another similar test.



Status bar below the menu toolbar shows system status, time into test or playback and test filename.

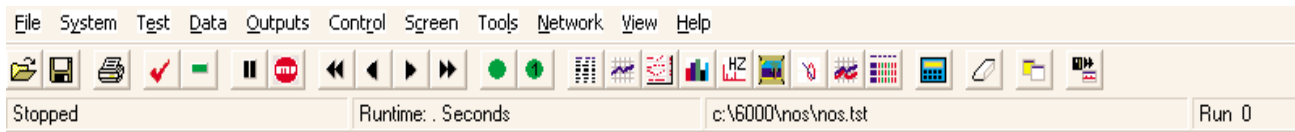

### **Recording is started by the operator, remote control or Alarms**

The remote control TTL input allows recording to be controlled by an external device. Data can overwrite the current file or be recorded in a new file that carries the test name, run number and ".dat" extension.

### **Single scan is used to record one pass through the scan table**

Record one pass through the scan list to an ASCII file. Each time the button is clicked or at selected time intervals a single scan is recorded. Single scan can also be initiated by a digital input at rates up to 1000 scans per second.

### **Preview, recording or playback is stopped by the operator, time out or remote control**

Use the stop button, a programmed recording time or the remote control input to stop recording. After stopping a data stamp containing test setup and calibration information is appended to the data file.

### **User Created Application Specific Menus**

The PI660 Component Module DLL (CMD) enables users to create their own menus and toolbars providing a means to customize operation. Not only can operation of the 6000 be changed but controls can be added for third-party and facility hardware and test control. Multi-level operating menus can be added that provide password control of privileges granted the operator. Or structure a test menu that requires specified operations or conditions to be met before proceeding with the next step. These are just a few examples of specialized operating menus that have been implemented for the 6000 using the PI660CMD and a glimpse of how the CMD can be used to customize application software.

*PI660 uses a variety of mechanisms to help the operator manage test setup and avoid costly mistakes*

**System programming**

System setup is done from a Channels Spreadsheet that may be selected to show all channels in the system or just those in the test. Once channels are selected for the test just click on the channel name to program channel parameters or on the sample rate to program it.

In addition to the basic channel configuration the spreadsheet gives information on the hardware setup and both gain and engineering units calibration of the channels. These mechanisms enable the operator to know at a glance the status of each channel in the test. This screen includes buttons for adding or deleting test channels, copy or moving channels, calibrating both gain and engineering units, making setup up reports and saving the test.

The screenshot shows a spreadsheet titled 'Select Test Channels' with columns for Function Name, Transducer Type, Units, Full Scale Range, V Cal Status, EU Cal Status, Conditioner Type, and Sample Rate. Callouts point to various elements: 'Right click on Name to spawn channel parameters programming screen' points to a channel name; 'Right click on Sample Rate to open sample rate programming screen' points to a sample rate value; 'Add or remove test channels' points to 'Add To Test' and 'Remove From Test' buttons; 'Channel setup status' points to the 'V Cal Status' and 'EU Cal Status' columns; 'Gain and EU calibration status' points to the 'EU Cal Status' column.

The screenshot shows a 'Test Readiness' dialog box with a table of checklist items. Callouts point to: 'Item passed readiness test' pointing to a 'Pass' status; 'Item not ready or completed' pointing to a 'Fail' status; 'Operator selected list items' pointing to a red circle icon; and 'Explanation of item discrepancy' pointing to the 'Summary' column.

Checklist Item	Status	Summary
Channel Setup	Fail	2 Channels Not Downloaded
Scan List Setup	Fail	Scan List Not Downloaded
Record Start Via Mark Line	Pass	
Record Acknowledge Of Mark Line Via Digital Out	Fail	Record Acknowledge Channel Problem
Fire Signal Setup	Fail	Pacific Fire Line Definition Problem
Voltage Cals	Fail	16 Channels Fail Voltage Calibration
EU Cals	Pass	
Max Recording Time	Pass	Maximum Of 1.0 Seconds Per Recording. 1 Recording Max
Data File Pre-Write	Pass	Datafile For Pacific Data Exists. Power Outage No Problem.
Backup System	Fail	No Network Connection To Backup System
Video System	Fail	No Network Connection To Video System
Record Signal Presence	Fail	Setup Invalid For Record Lines
Fire Signal Presence	Fail	Setup Invalid For Fire Lines
Run Number Incrementing	Pass	Enabled. Starting Run Number 4
Multiple Recording Re Arm	Pass	Enabled
Test File Saving	Pass	Test Saved

**Test readiness review**

Use the test readiness review to verify that the system is configured and ready to record test data. User configured it can check that channel parameters have been downloaded to hardware, there is sufficient disk space for recording, all desired calibrations have been performed, the backup system is on-line and programmed, the test file is saved and more. Use it to avoid mistakes that could result in the loss of valuable test data.

**Operation Logging**

PI660 enables the test operator to log operations to a text file that is saved with the test and can be viewed and printed using a text editor or word processor. If there are questions concerning test setup or operating procedure just refer to the test log file. It also creates text files containing channel hardware set up and reports any differences between hardware set up and software programming.

# CHANNEL SETUP IS QUICK AND SIMPLE

*PI660 simplifies channel setup by including a number of tools that help speed test preparation*

The screenshot shows the 'Channel Definition' dialog box with several callouts:

- Enter channel name and description:** Points to the 'Channel Name' and 'Description' fields.
- Select measurement type and engineering units:** Points to the 'Measurement Type' (Acceleration) and 'Units For Measurement' (Standard Units, g's).
- Enter third-order polynomial for calibrated displays and export:** Points to the 'Engineering Unit Conversion Equation Coefficients' table.
- Set gain, filter and transducer excitation:** Points to the 'Gain' (5000), 'Filter' (WideBand), and 'Excitation' (Voltage) settings.

## Programming by menu selection

Gage type selection determines channel settings that are available and in some cases Engineering Unit conversions that will take place. Automatic gain generation based on expected full-scale measurement value is provided. Channel definitions can be copied, moved, or swapped easily, and channel hardware can be configured and verified from the channel definition screen.

## Programming by database or spreadsheet

Program 6000 operating parameters by downloading Access database files. Use a spreadsheet or database program to set up a test then download the Access compatible file to PI660. Last minute changes can be made using PI660's menu-based screens then uploaded to the program that created the Access files. Design custom forms for operator programming. Make custom reports to print test setups, calibration and test data.

The screenshots show the 'Channel Parameters' dialog and two reports:

**Channel Parameters Dialog:**

- Name: Rear Axle
- Units: Gs
- Description: Accelerometer on rear axle
- Gain: 300
- Filter: 0
- Excitation Voltage: 10
- Sensitivity: 0.534903166420655
- Offset: 0.957921939736
- CalProcedure: -1
- CardType: 6033

**Channel Parameters Report 1:**

Channel Name	Units	Description	Gain	Filter	Excitation	Sensitivity	Offset	CalProcedure	CardType
0	Rear Axle	Accelerometer on rear axle	300	0	10	0.534903	0.957921	-1	6033
1	Body Flex	Accelerometer on rear axle	1	0	10	1	0	-1	6033
2	Body Flex	Accelerometer on rear axle	1	0	10	1	0	-1	6033
3	Motor Drive	Drive voltage	1	0	10	1	0	-1	6033
4	Front Axle	Accelerometer on front axle	300	0	10	0.534903	0.957921	-1	6033
5	Frame, rear	Strain gage on frame	1000	0	10	300	0.024	-1	6033
6	Frame, front	Strain gage on frame	1000	0	10	300	0.024	-1	6033
7	Motor Temp	Thermistor on motor	500	0	10	5	0	-1	6033

**Channel Parameters Report 2:**

Channel Name	Units	Description	Gain	Filter	Excitation	Sensitivity	Offset	CalProcedure	CardType
0	Rear Axle	Accelerometer on rear axle	300	0	10	0.534903	0.957921	-1	6033
1	Body Flex	Accelerometer on rear axle	1	0	10	1	0	-1	6033
2	Body Flex	Accelerometer on rear axle	1	0	10	1	0	-1	6033
3	Motor Drive	Drive voltage	1	0	10	1	0	-1	6033
4	Front Axle	Accelerometer on front axle	300	0	10	0.534903	0.957921	-1	6033
5	Frame, rear	Strain gage on frame	1000	0	10	300	0.024	-1	6033
6	Frame, front	Strain gage on frame	1000	0	10	300	0.024	-1	6033
7	Motor Temp	Thermistor on motor	500	0	10	5	0	-1	6033

The screenshot shows the 'Copy Channel Information' dialog box. It has two columns: 'Source Channel' and 'Destination Channel(s)'. Both columns list various channels like Accelerometer, Wave Form, Twanger, Microphone, Pacific DAS - 5 through -13, Wise Gage, and Pacific DAS - 10 through -12. There are checkboxes for 'Copy These Selected Fields' including Function Name, Full Scale Range, Transducer Type & Units, Description, Location, Gain, Filter, Excitation, Autobalance, Autozero, Calibration Information, Special Cal Options, EU Conversion Equations, and Alarms. There are 'Cancel' and 'Copy & Exit' buttons.

## Multiple similar channels

Lots of similar channels to program? Duplicate the programming of a selected channel to one or many other channels. Then just rename the copied channels.

## Calibrating for highest accuracy measurements

### Gain and engineering units calibration

PI660 provides two complementary modes of calibration. They are gain and zero calibration and engineering unit (EU) calibration. PI660's screens allow the user to calibrate one or more channels concurrently and to quickly spawn calibration setup and channel definition screens. Results are tabulated, and displayed along with visual indicators of pass/fail. User defined tolerances determine the error bands to apply. PI660 uses the calibration equations to convert voltage measured to EU for real-time data display, data playback, and data export.

Voltage calibration enables PI660 to develop a transfer function between millivolts measured and millivolts traceable. Zero and gain corrections are automatically applied to acquired data.

Calibrations are thoroughly checked against user specified limits for linearity, flat line, zero, noise, overload and hysteresis.

Function Name	Status	Noise +0.0%	Deviation +0.0%	Mean +0.0%	Deviation -0.0%	Mean -0.0%
OK Accelerometer	OK	1.5892	0.0001	-1.8158	0.0001	1.1895
OK Wave Form	OK	1.5898	0.0007	-1.8150	0.0002	1.1897
OK Tweezer	OK	1.5890	0.0007	-1.8139	0.0007	1.1894
OK Microphone	OK	1.5893	0.0004	-1.8145	0.0003	1.1890
Fail Pacific DAS - 5	Fail Line Error				0.0002	1.1883
Fail Pacific DAS - 6	Fail Line Error				0.0005	1.1895
Fail Pacific DAS - 7	Fail Line Error				0.0003	1.1888
Fail Pacific DAS - 8	Fail Line Error				0.0005	1.1888
OK Wave Sarge	OK				0.0001	1.1885
Fail Pacific DAS - 10	Fail Line Error				0.0001	1.1897
Fail Pacific DAS - 11	Fail Line Error				0.0001	1.1890
Fail Pacific DAS - 12	Fail Line Error				0.0001	1.1891
Fail Pacific DAS - 13	Fail Line Error				0.0001	1.1887
Fail Pacific DAS - 14	Fail Line Error				0.0002	1.1893
Fail Pacific DAS - 15	Fail Line Error				0.0002	1.1894
Fail Pacific DAS - 16	Fail Line Error				0.0001	1.1890

Up to eight-step EU calibrations performed interactively or automatically. EU calibration develops a transfer function between millivolts traceable and engineering units.

Plot individual calibration steps and data from previous calibrations. Delete steps, replace with selected steps from another calibration or replace entire calibration if desired.

Function Name	Error	Gain	Mean 1	Deviate 1	Mean 2	Deviate 2
OK Accelerometer	Fail Line Error	1.0000	0.0000	0.0000	0.0000	0.0000
OK Wave Form	OK	1.0000	0.0000	0.0000	0.0000	0.0000
OK Tweezer	OK	1.0000	0.0000	0.0000	0.0000	0.0000
OK Microphone	OK	1.0000	0.0000	0.0000	0.0000	0.0000
OK Pacific DAS - 5	OK	1.0000	0.0000	0.0000	0.0000	0.0000
OK Pacific DAS - 6	OK	1.0000	0.0000	0.0000	0.0000	0.0000
OK Pacific DAS - 7	OK	1.0000	0.0000	0.0000	0.0000	0.0000
OK Pacific DAS - 8	OK	1.0000	0.0000	0.0000	0.0000	0.0000
OK Wave Sarge	OK	1.0000	0.0000	0.0000	0.0000	0.0000
OK Wave Sarge	OK	1.0000	0.0000	0.0000	0.0000	0.0000

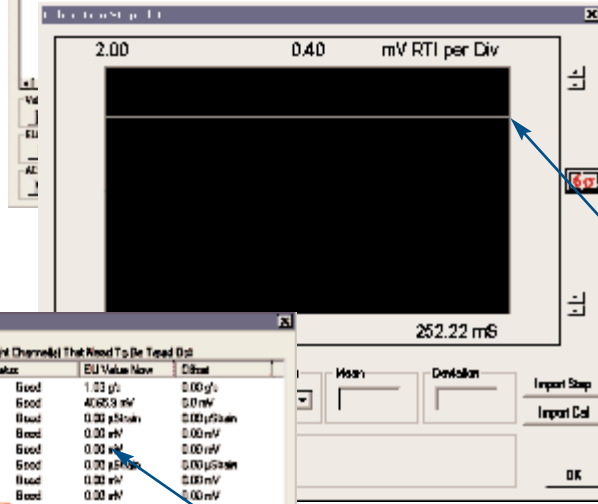

Automatically remove measured tare from measurement data.

*The Control Processor may be user programmed to produce control or data outputs, mathematically derive parameters or generate waveforms*

## **Built-in algorithms**

PI660 DSP programming is built on the concept of Solutions each of which contains up to twelve DSP algorithms that are executed sequentially. To create a Solution, the user adds algorithms to a project and maps the algorithm's inputs and outputs to measurement channels, memory locations, data bus outputs and the Control Processor's analog and digital outputs. The user then downloads the solution to the Control Processor's static RAM and initiates its execution.

Each algorithm in the solution works with other algorithms in the project. When an algorithm finishes execution, the results are placed into memory where they can be used to drive DAC outputs or as inputs to other algorithms. When the next algorithm executes, it retrieves information from defined memory locations, or user selected channel inputs, processes the data, and continues the sequence. When all algorithms have been processed, the solution cycle can be started again.

The example shown is a simple solution with two algorithms that converts binary measured channel data to engineering units applying user entered slopes and offsets and outputs the engineering units data as an analog signals on the DACs.

## **User developed algorithms**

Algorithms for the Control Processor can be developed using the Texas Instrument Code Composer Studio Software Development Kit (SDK). Once developed, the algorithm is compiled into executable code, debugged using one of many available emulators, and downloaded to the DSP's memory for execution. A significant feature of the Model 6042 is that it allows debugging of user developed algorithms directly on the DSP hardware. Just attach a debugging pod to the JTAG port and step through the program execution while observing the results using PI660.

User developed algorithms can be saved in the Control Processor's non-volatile flash RAM, which avoids downloading from the host computer each time they are used.

## **Derived parameters**

The DSP on the Control Processor provides a fast and efficient means of deriving parameters from measurement data without consuming processor resources in the system CPU. Use built-in or user developed algorithms to process data from one or more measurement channels then output the new parameter on one of the Control Processor's sixty-four data bus outputs. Like measurement channels these data bus outputs can be selected for recording and display.

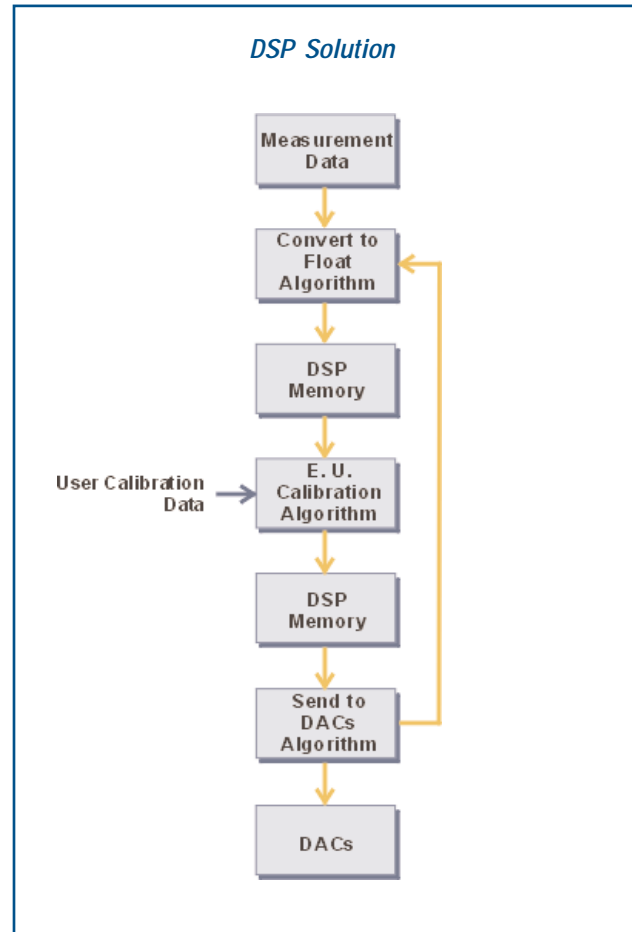

## **Derived Parameters Using the Math Engine**

The math engine in PI660XP and XPS is another way to derive parameters from measurement data for display and recording. Each computed parameter can use up to nine measurements along with constants, +, -, \*, /, (). ;, div, mod, sin, cos, tan, sqrt, pow, atan, asin, acos, log10, log2, exp, ln, inv, abs, sinh, and cosh. Mathematical equations are written in a straightforward manner and are performed each time the current value display table is updated. Two sets of high and low alarm limits, with operator selected display colors, are provided for each derived parameter and checked for each calculation.

*PI660 is available in full-performance Professional, Professional Server, Client Display and Basic Acquisition & Display versions. All versions except the Client support high-speed recording at rates up to 150 MS/s*

Version	PI660XP	PI660XPS	PI660C	PI660SP
Features	Professional	Professional Server	Client Display	Basic Acquisition & Display
<b>Math Engine</b>				
Component Module DLL (CMD)	✓	✓	✓	
Client support		✓		
DSP support	✓	✓		
SCRAMNet support	✓	✓		
Automatic Backup System support	✓	✓		
High-Speed Acquisition support (150 MS/s)	✓	✓		✓
Third-party hardware support (request current list)	✓	✓		
Video farm client support	✓	✓		
<b>Programming</b>				
Autoconfigure	✓	✓		✓
Multiple data sources	✓	✓		
Select test channels	✓	✓		✓
Tool tips	✓	✓	✓	✓
Program operating parameters	✓	✓		✓
Database programming, import/export	✓	✓		✓
Report gallery	✓	✓		✓
<b>Operation</b>				
Operational logging	✓			
Single scan and triggered scan	✓	✓		✓
Ring (History) buffer support	✓	✓		✓
Test readiness check	✓	✓		
Analog control (using PCI DAC and CMD)	✓	✓		
5500/9300 programming support	✓	✓		
Export data files, ASCII & binary	✓	✓		✓
<b>Displays</b>				
Replay recorded data to displays	✓	✓		✓
Current value displays, tabular, bar, stripchart, picture	✓	✓	✓	✓
History displays, oscilloscope, fft, waterfall	✓	✓	✓	✓
Multiple display pages	✓	✓	✓	✓
Alarms display	✓	✓	✓	✓
Output and replay to DACs (DAC Client support)	✓	✓		
<b>Calibration</b>				
Autozero and Autobalance		✓		✓
Polynomial engineering units	✓	✓	✓	✓
Voltage calibration	✓	✓		✓
Shunt calibration	✓	✓		✓
Automatic gain correction	✓	✓		
Plot calibration data	✓	✓		
Calibration validation	✓			
Import or change calibration data	✓			
Line compensation	✓	✓		
Thermocouple reference compensation	✓	✓		✓

# OPERATOR AND DISPLAY WORKSTATIONS

*PI660 contains built-in support for networked workstations that display, output data and transparently record a backup of critical data*

## **Operator workstation**

The Operator Workstation is a PC running Windows 2000 or XP and PI660 basic, professional or professional server. It programs and controls the 6000 data acquisition systems, records data to hard drive or RAID and displays the data for the operator. The Server version of PI660 distributes real-time data to PC workstations for display and output.

## **Display workstations**

Several experimenters can simultaneously view real-time test data using the Client software on a PC platform with Windows when the Server software is installed on the Operator Workstation. Each Display Workstation can select to view any measurements in any of the supported graphical or numerical formats with alarm indicators.

## **DAQ workstation**

The DAQ Client Workstation provides up to 64 analog outputs from any of the measurements recorded by the Operator Workstation. Up to four sixteen-channel DACs are supported by the DAQ Client software that can be assigned to any measurement channel and scaled to the user's requirements.

## **Video farm**

The Video Farm may be used for displaying data in a large scale format, i.e. "video wall", or for multiple displays where the viewers do not need the ability to change displays or parameters. A Video Farm workstation supplies video outputs for up to nine display monitors. It selects the display types, measurements in each display and measurement scaling for each monitor.

## **Backup system**

PI660XP and XPS support a second recording system for backup of critical test data. The backup system typically consists of an industrial grade PC chassis with processor, PCI backplane and one or more ADC cards. High level analog data is routed from the 6000 input module's high-level analog outputs to the inputs of ADC channels in the backup system. PI660 programs and controls both systems and once set up the backup system does not require any additional attention from the operator. The backup system channels are calibrated when the primary system is calibrated and its operation is completely transparent to the system operator.

