

The 6044 has 32 discrete digital outputs that may be directly programmed, or programmed to automatically change state when the output of one or more measurement channels in the same enclosure violate user specified alarm limits. It is usually employed to control external devices for automatic throttle-back, shutdown of test stimuli or to notify the control system or operator of critical parameters. Up to three 6044s may be installed in a 6000 Series enclosure.

The logic may be configured so that the limits of multiple channels control a single discrete output. This multipurpose configuration can be expanded to any number of channels in the same enclosure. Each discrete output has programmable persistence. If persistence is used, each alarm limit violation counts up until the persistence value is reached before setting the discrete output state. Likewise, absence of an alarm limit violation counts down before clearing the discrete output state. Alarm limits are checked for each sample of data.

In addition to its function as an alarm generator, the 6044 may be used to provide programmed discrete digital outputs and to respond to changes of state on the 6000 system-wide Warning and Alarm bus. It can also map the digital output of measurement channels and digital signal processor to the discrete outputs.

Outputs are programmed in two groups of sixteen to have TTL or open collector outputs. The outputs may be programmed to follow their input channels in and out of alarm or may be latched, requiring operator intervention to release the alarm state.



FEATURES

- Generate discrete output state based on limits set for channels in the same Series 6000 enclosure
- 32 Discrete digital outputs
- TTL or open collector
- Programmable limits and persistence
- Respond to system wide alarms
- Programmable discrete outputs

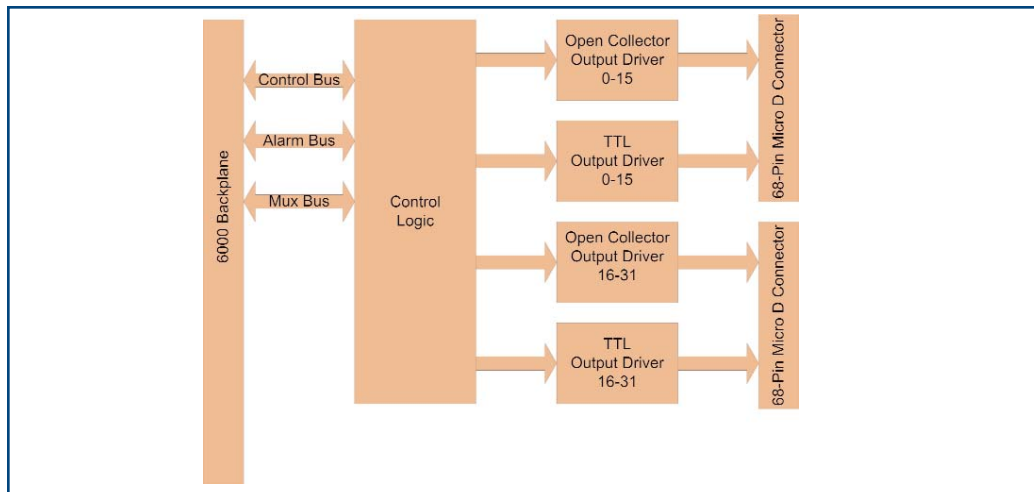

SPECIFICATIONS

OPERATION

Number32 discrete outputs in two groups of 16.
 Mode.....Each discrete output can respond to one of three data sources: 1) data words sent via the system interface, 2) comparison of data from measurement channels in the same enclosure to programmed limits and 3) the 6000 system alarm bus.
 ProgrammingOutput data word is loaded by program instruction during time when measurement data is not being sent to the computer. Latency will depend on system throughput rate and scan table programming.
 Alarm OutputsPreprogrammed output discrete set high or low in response to alarm violation. Latency is less than 2 sample periods from the digitizing of signal causing alarm.

OUTPUT LOGIC LEVELS

TTLOn is +4.8 Volts minimum; off is +0.15 Volts maximum from 1K Ohm source impedance.
 Open-Collector+5 Volt maximum external power source, 200 mA maximum sink current.

GENERAL

MountingOccupies one slot in Series 6000 enclosures.
 Connectors.....Two 68-pin Micro DB68 (SCSI-3) connectors. Connectors are located on the front and 6-foot cables with breakout panels are supplied.
 Temperature.....0°C to +50°C.
 HumidityUp to 95% without condensation.

ORDERING INFORMATION

6044.....Discrete Output and Alarm Module